



Dual Color LED Bulb Installation Manual (H8/H/11/H16, HB4 (9006), PSX26W)

LED Bulb lighting test points ※Do it before installment.

<Test procedure>

1. Remove the vehicle connector from halogen bulb connector.
2. Connect LED bulb connector to the vehicle connector.
3. Turn on your fog lamp and test for correct lighting.
4. Check the vehicle gauges for any warning signs shown.
If no warnings, the test is finished.

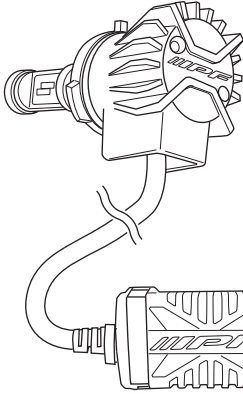

⚠ Warning

Do not turn on the switch if the bulb is not connected.

LED bulb connector
<Non-polarity>

Vehicle connector

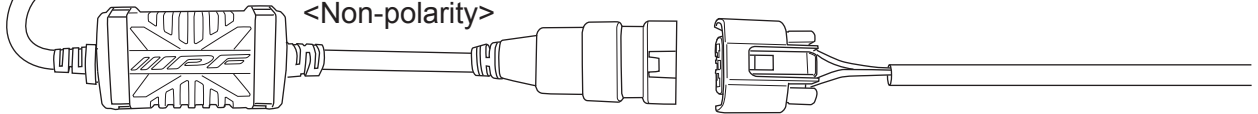

LED Bulb fitting

H8/H/11/H16, PSX26W type

Space around the bulb

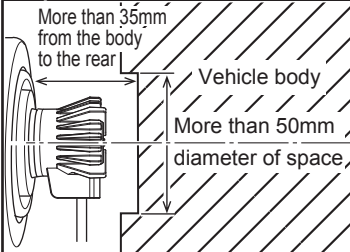

⚠ Confirm there is enough space to allow full range of the fog lamp's movement.

Direct contact with water, dirt or dust

Bad
<Fender liner is not attached>

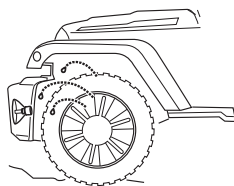

✗ Incorrect

HB4 type

Space around the bulb

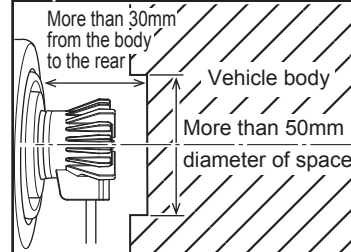

⚠ Confirm there is enough space to allow full range of the fog lamp's movement.

Direct contact with water, dirt or dust

Bad
<Fender liner is not attached>

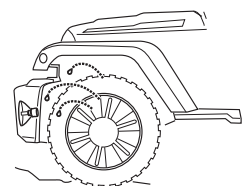

✗ Incorrect

Components

LED Bulb Assy ... 2

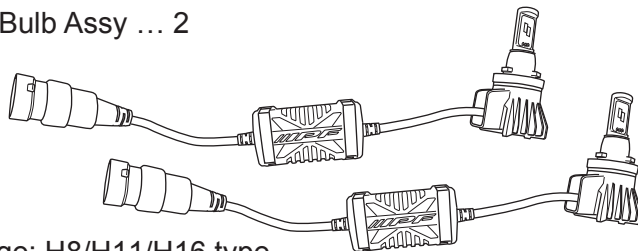

*Image: H8/H11/H16 type

Cable ties...4



Hex wrench...1



*Not used in PSX26W type

Installation procedure

1 Halogen Bulb Check

Check the condition of the halogen bulb attachment.

If the check cannot be done visually or the space is too narrow, please remove the front bumper or surround component from the vehicle.

Refer to the vehicle's manual when changing or removing the halogen fog lamp bulb.

2 Removing the Halogen Bulb

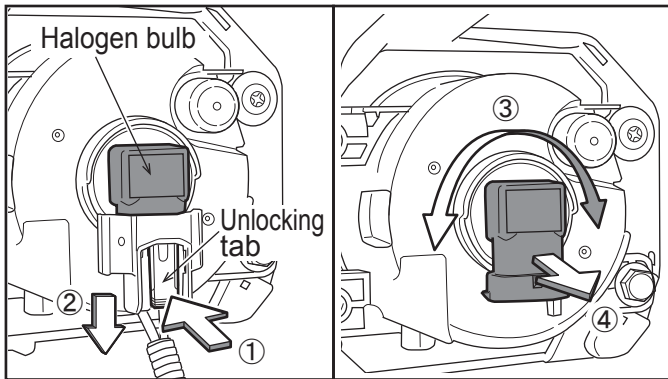

Remove the bulb by referring to the figure **2**.

- ① While still pushing the tab, pull the connector from the bulb.
- ② Remove the connector.
- ③ Turn the bulb clockwise or counter clockwise.
- ④ Remove the bulb.

⚠ Caution

- Rotation direction of turning/removing the bulb may vary depending on the vehicles or the fog lamp position (right or left side). Install it after confirmation of vehicle installation instruction.
- In H8/H/11/H16 bulb type, the unlocking tab may be on side surface of vehicle connector.
- In PSX26W type, remove the connector in the rear of the vehicle direction.

3 Installing the LED Bulb

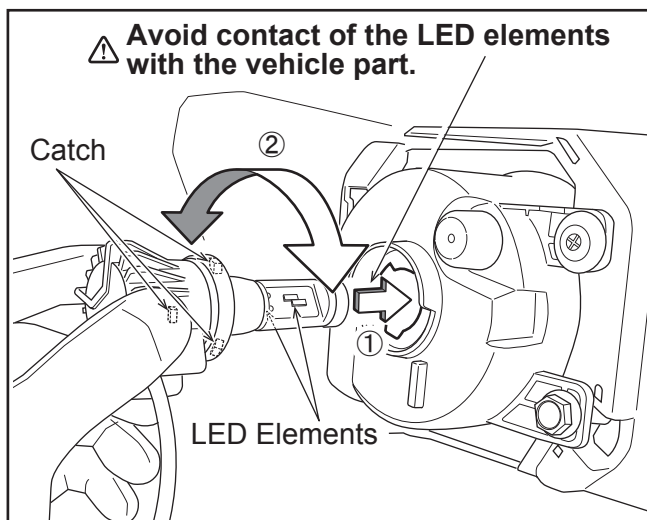

Refer to the figure **3**.

- ① Insert the LED bulb into the fog lamp aligning it with the three grooves.
- ② Turn the LED bulb clockwise or counter clockwise to lock it into place.

⚠ Warning

Don't rotate it by excessive power. Also don't rotate by tool.

⚠ Caution

- Rotation direction of turning/removing the bulb may vary depending on the vehicles or the fog lamp position (right or left side). Install it after confirmation of vehicle installation instruction.
- When inserting the LED bulb, be careful not to hit the LED elements on the edge of headlamp etc.
- If the LED element becomes scratched, the brightness or light distribution might reduce in range and the vehicle might not meet the standard requirements in a vehicle inspection.

4 Angle Check *Except PSX26W type

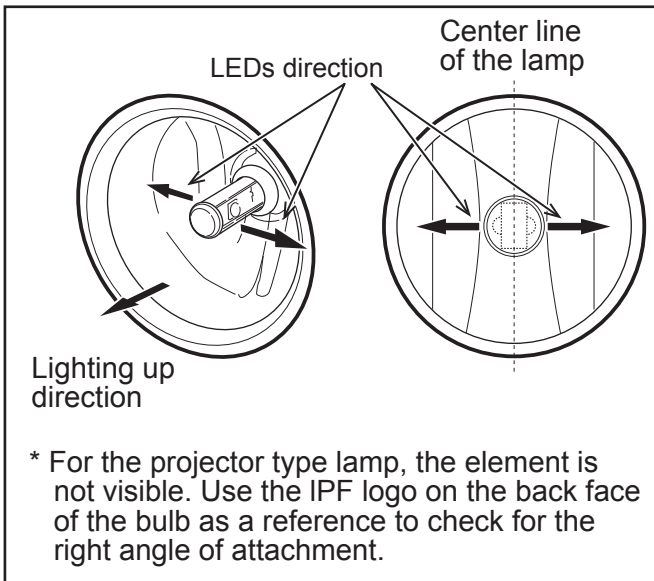

When facing the front lens of the fog lamp, verify that the LED elements facing toward right and left refer to the figure left.

If the LED elements are not facing toward right and left properly, go to step **5** and adjust the angle of attachment (H8/H11/H16, HB4 type).

After confirming the right position of LED elements then proceed to step **6**.

Warning

If the angle of attachment is not level when installed, the brightness or light distribution might reduce in range and the vehicle might not meet the standard requirements in a vehicle inspection.

Caution

In H16 halogen bulb type, all vehicles are required to adjust the angle of attachment. H16 socket's attaching portion is various in form.

Please go to step **5** and adjust the angle of attachment.

5 Angle Adjustment *Except PSX26W type

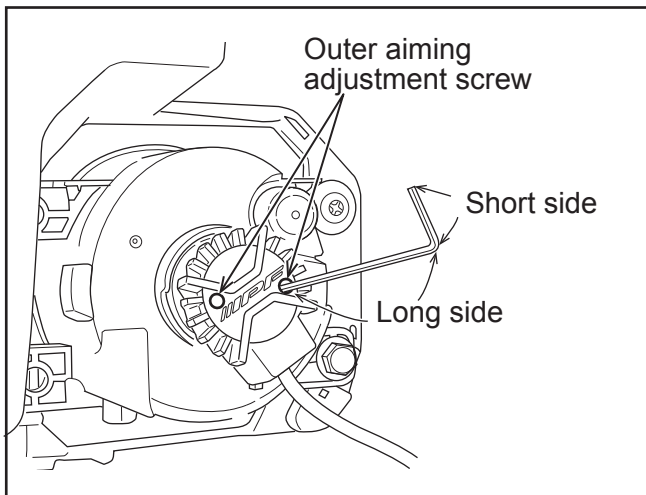

If the angle of attachment is not in the right position, adjust it using the long side of hex wrench by loosening the outer aiming adjustment screw (two points), rotate the bulb and fix the angle. When finished the adjustment, secure the outer aiming adjustment screw (two points), and go back to step **4** to check the angle of attachment.

Caution

This product carries the outer aiming feature which enables you to adjust bulb angle after installment procedure was finished.

Adjustment can be done while you check light distribution by lighting up at a wall or screen in front of the vehicle. Wear heat-resistant gloves in this case, because LED bulb body becomes hot when lighting up. There might be a danger of burn yourself if you touch it barehanded.

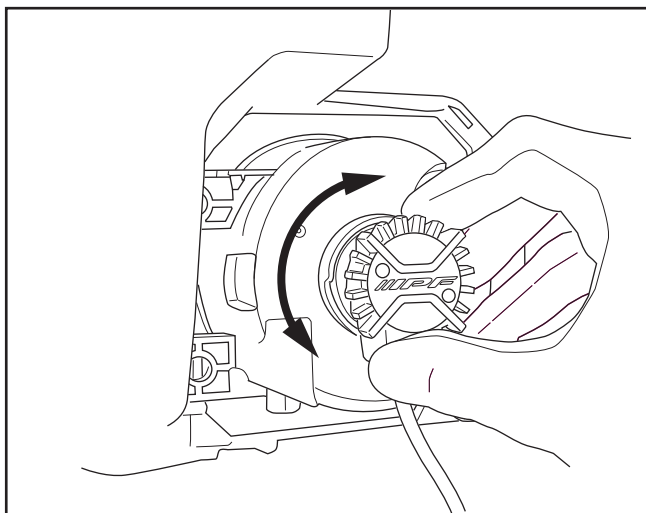

Warning

It causes a damage or installing/removing fault if you apply excessive or insufficient power to tighten the adjustment screw of the outer aiming feature.

Recommended torque: 0.2-0.5N · m

Do not remove or loosen the screw as shown below.

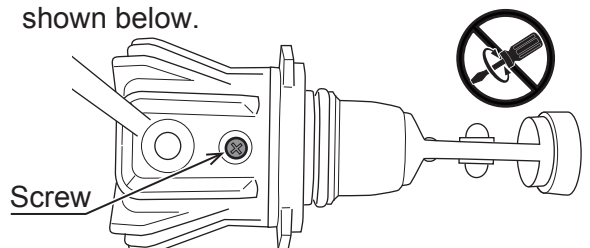

6 Connecting the connector, fixing the drive unit and harness

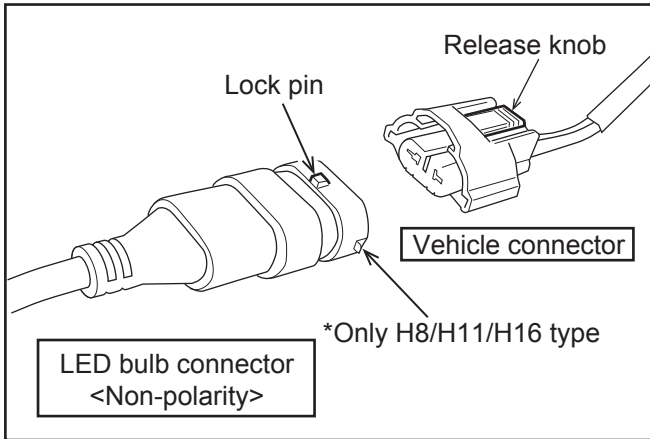

Connect the LED bulb connector with the vehicle's connector. Insert the connector all the way and align the lock pin. Make sure the connector is locked into place.

⚠ Caution

In rare cases, the connector does not lock into place. Secure the connection with electrical tape.

The release knob may be on the side of vehicle's connector. (H8/H11/H16 type)
Be sure the drive unit and harness are not interfered with vehicle parts (a washer tank or horn etc).

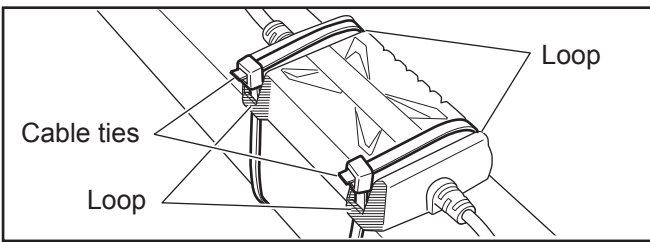

Insert cable ties into the loops and fix them in the right place near the fog lamp.

Verify that the LED bulb is secured tightly by wobbling it. If you removed front bumper or other parts, reinstall them into original positions.

⚠ Warning (Prevent disconnecting)

Do not tie the harness together with the drive unit.

Do not bend or pull the harness by excessive power.

Leave a slack in the harness. Harness's minimum bend radius should be more than 20mm (see the figure right).

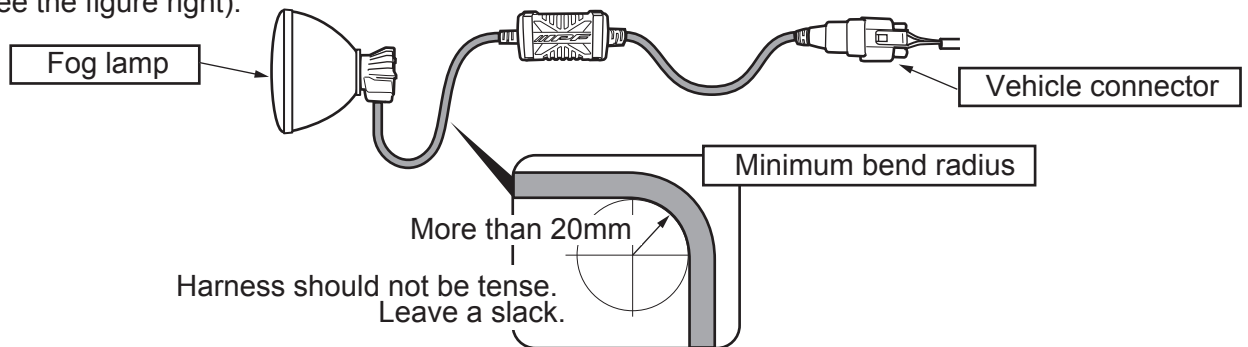

7 Lighting check and adjusting optical axis

Turn on the engine. Switch on the fog lamp. Check to see if the LED bubs light up properly. Make adjustment to the optical axis refer to the figure below. Check to see if the fog lamp indicator on the dash is lighting up properly.

Optical axis

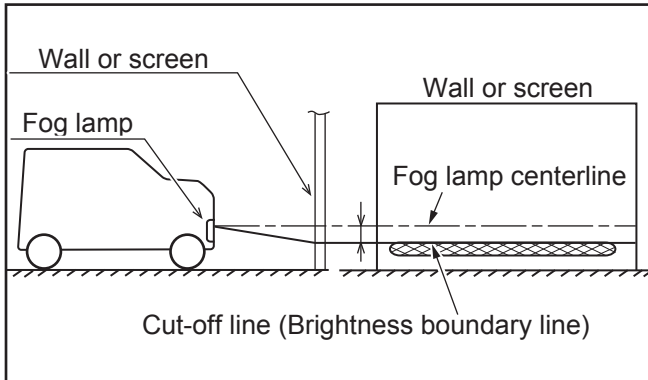

Park your vehicle in a flat place. Turn on the fog lamp (white light) towards a wall or screen. Adjust the optical axis so that a cut-off line (brightness boundary line) comes below the centerline of the fog lamp.

For more information about an optical axis adjustment method, please check it with car maintenance books you have or from your dealer.

Advice

In general vehicles, rear wheel side sinks by loading to trunk or getting into backseats. It makes an optical axis upward.

This product is brighter than factory halogen fog lamp bulb. Upward lighting by such optical axis reduces proper fog lamp function and it may cause a glare to oncoming or leading vehicles.

Assume that load capacity on backseats or trunk and adjust to lower a cut-off line (brightness boundary line) beforehand.

How to switch two LED colors

This product can produce white and yellow LED colors.

Users can choose and switch LED colors depending on weather and driving environment.

Advice

White LED color provides further reaching beam pattern.

Yellow LED color provides light near side of the vehicle. Use when in poor weather conditions.

Caution

When changing LED colors, park your vehicle. Follow the regulations when using fog lamp.

1 Turn on the Fog Lamp

Turn on the vehicle's fog lamp switch.

2 Switch LED Colors

Turn on and off the vehicle's fog lamp switch twice in a row. LED color will switch from one color to another.

Switch from white color to yellow color

Light ON (white) ⇒ OFF ⇒ ON ⇒ OFF ⇒ Light ON (yellow)

Switch from yellow color to white color

Light ON (yellow) ⇒ OFF ⇒ ON ⇒ OFF ⇒ Light ON (white)

*Fog lamp switch images.

Switch's design varies depending on vehicles.

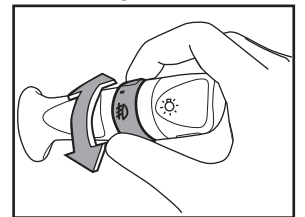
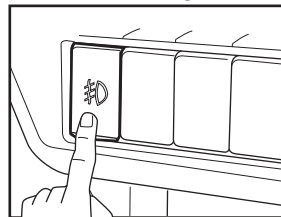

Advice

Turning on and off fog lamp switch twice in a row within two seconds. Exceeding two seconds, it automatically resets to current light mode.

Start switching LED color operation when the fog lamp is on.

If you switch LED light color once again, wait six seconds from the last switching operation.

Reset the memory function if the right and left fog lamps are on in different LED light colors.

Please follow the procedure below if the two fog lamp's LED color mismatched.

How to set back to factory preset mode (white color).

Turn on and off the vehicle's fog lamp switch four times in a row.

Light ON (R/L in different colors) ⇒ OFF ⇒ ON ⇒ OFF ⇒ ON ⇒ OFF ⇒ ON ⇒ OFF ⇒ Light ON (R/L in white color)

*Reset the memory function withing five seconds.

Please contact your nearest store or IPF dealers if LED colors unmatched often.